

This PDF is a selection from an out-of-print volume from the National Bureau of Economic Research

Volume Title: Short-Term Macroeconomic Policy in Latin America

Volume Author/Editor: Jere R. Behrman and James Hanson, eds.

Volume Publisher: NBER

Volume ISBN: 0-88410-489-3

Volume URL: <http://www.nber.org/books/beh79-1>

Publication Date: 1979

Chapter Title: Econometric Forecasting for Mexico: An Analysis of Errors in Prediction

Chapter Author: Abel Beltran del Rio

Chapter URL: <http://www.nber.org/chapters/c3885>

Chapter pages in book: (p. 115 - 132)

4

ABEL BELTRÁN
DEL RIO

Econometric Forecasting for Mexico: An Analysis of Errors in Prediction

The central question about the utility of econometric models relates to their predictive accuracy. While evaluations have been made of predictions generated by developed country models,¹ no such attempt has been made for econometric forecasts of developing countries.

Evaluations may be made either through an analysis of the usual statistics of fit of the estimated equations of the model—the correlation coefficients, *t*-statistics, and Durbin-Watson statistics—or through a consideration of the (ex post) predictive accuracy of the forecasts over the sample period, which is the usual method.² It is evident, however, that an evaluation made a posteriori, based on ex ante prediction, is more satisfactory. This approach does require a relatively long period of predictions for computing the errors through a comparison of the actual figures with predictions made at different times. Such a procedure not only permits an appreciation of the relative magnitude of errors in the predictions made with different time horizons, but also illustrates whether the errors are reduced as the time horizon shortens.

The accumulated experience of the Wharton EFA econometric

project for Mexico (DIEMEX) provides a vehicle for this type of evaluation. More than seven years of regular forecasts have been made using successive versions of the annual econometric model. From this experience we choose to present, for purposes of this study, an evaluation corresponding to Version V of the model, which is presently in use. Before performing that evaluation it is necessary to describe the model briefly.

DIEMEX-WHARTON EFA MODEL V

Version V of the Mexican econometric model was finished in 1971 and has been used uninterruptedly since that time in making *ex ante* projections.

The model consists of 143 equations, of which 40 are estimated. The rest are identities. There are 46 exogenous variables. The model generates forecasts of the components of aggregate demand, the external balance on current account, aggregate output, labor force, certain demographic variables, accumulation of capital and creation of productive capacity, public finances, prices, and wages.³ Basically it is concerned with real variables and contains a minimum of monetary detail. The equations were estimated using ordinary least squares.

The flow chart—Figure 4-1—provides a condensed description of the model and its six endogenous blocks. The economic process delineated there contains the following lines of causation among the blocks, which are numbered in parentheses in what follows: the magnitude of internal demand and its decomposition into consumption and investment in (1) determine the accumulation of capital and generation of productive capacity (3), with effects upon the demand for labor (4) and the division of income (5). Internal demand and its composition also determine the magnitude and composition of imports (especially the division of imports into consumption and investment goods, which is not shown in the diagram) within (1). The imports are (partially) paid for with exports, also within block (1), all of which is detailed in nine of the model's equations. Exports depend fundamentally on the U.S. economy, which is the most important exogenous factor in the model.

The rest of the diagram shows that production (2) is the result of demand (1). The demographic process of (4)—population and urbanization—depends on the regional distribution of capital and the creation of productive capacity (3). The distribution of income (5) is the result of the general level of economic activity determined in (1), of demand for labor, and of wages and prices. These last two

Figure 4-1. Mexico Macro Model—Condensed Flow Chart

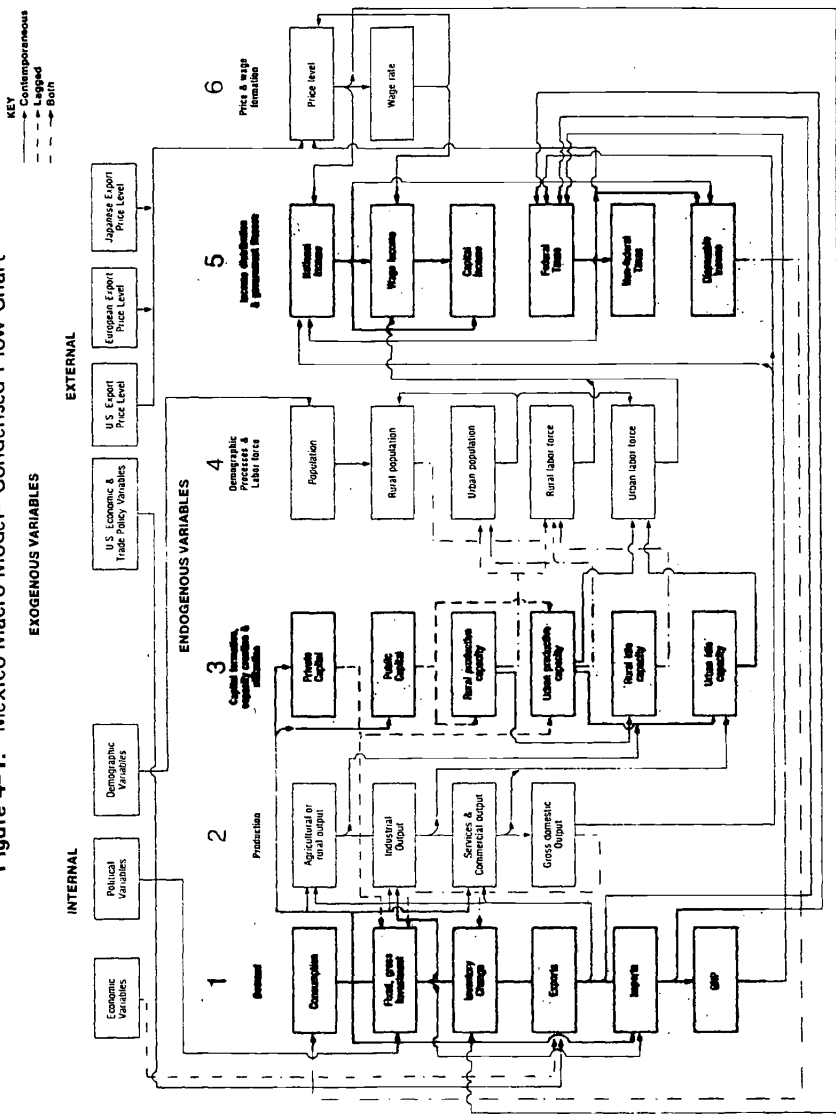

variables are interdependent and also depend on exogenous and endogenous processes.

The level of prices is affected by external inflation (United States, Europe, and Japan), by unit labor costs, and by indirect taxes. Finally political factors, taken as exogenous, affect the magnitude and composition of demand in (1), particularly investment.

PREDICTIVE METHOD

The forecasts that we will analyze were made between mid-year 1971 and the end of 1974, approximately every semester; the only exception being the forecast that normally would have been made in the first part of 1973, which in fact was postponed to September of that year.

Usually more than one set of predictions is made in a semester. This is done for two reasons. At times when uncertainty exists about the direction that domestic economic policy will take, the most probable policy outcomes are used to generate two or more predictions. In addition, our procedure, following the method used by Wharton EFA with its U.S. models,⁴ consists of a preliminary projection and a revision (or revisions in the above case). These revisions are done in the semestral meetings of the economists representing the institutions that participate in the Wharton-DIEMEX project. In addition, the revisions incorporate corrections and suggestions from informed economists who do not belong to the DIEMEX group.

These consultations with both groups are an important source of information regarding the levels of exogenous variables in the model and the behavioral equations through adjustment of their errors for the period of projection. This is especially true for the short run as we indicate below. It should be emphasized that frequently these adjustments to the estimated equations are considerable. In general we are correcting the equation in question with more recent knowledge of the expert in the area and/or incorporating official revisions in the data.

Such a predictive procedure is neither simplistic nor mechanistic—in comparison to a simple extrapolation (by using, for example, the growth rate in the exogenous variables and “freezing” the last regression error of the behavioral variables for the period of projection). The comparison of the predictive errors generated by both methods, the simplistic versus the one we follow, favors the approach used here, as shown in Table 4-7 which will be discussed below.

THE ERRORS OF PREDICTION: PERCENTAGES AND DIFFERENCES

A simple way of illustrating the magnitude of the errors obtained in the predictions made since mid-1971 is to compare in tabular form the published official figures with the projections and compute the percentage errors, taking the official figure as 100 percent.

where

$$E_t = (P_t - A_t)/A_t$$

P_t = projection of level or flow;

A_t = actual figure

In the case of rates of growth, the absolute difference between actual and projected growth rates is perhaps a more convenient way to calculate errors in this type of variable.

where

$$D_t = (P_t - A_t)$$

P_t = projected rate of growth

A_t = actual rate

These two forms of calculation have been used in the tables that follow.

Since at the time this paper was written the published figures for 1972, 1973, and 1974 were available, we have taken the corresponding projections that were made for these three years. Here it should be mentioned that the Mexican authorities (fundamentally, the Banco de Mexico) publish preliminary figures for the previous year in March and revised figures in September. Thus the figures for 1972 and 1973 are revised while those for 1974 were still preliminary at the time of writing.

Tables 4-1, 4-2, and 4-3 contain in the top ten rows, the percentage errors (E_t) made in the projections (P_t) of the levels based on the actual figures (A_t) (taken as 100 percent), which are shown in the last column. Aside from the price deflator of GDP, expressed with base 1950 = 1.00, and federal government income and income taxes, which are expressed in billions of current pesos, all variables are expressed in billions of real 1950 pesos. (Rows 11 to 20 present the errors in predicted growth rates (D_t) with the final column reproducing the actual growth rates. The last two rows of these tables, 21

Table 4-1. Errors of 11 Ex Ante DIEMEX-Wharton Forecasts: Forecasted Year 1974

Forecast	Row Symbol	Concept	Forecasted Year 1974											Actual Value 1974
			1 Jun. 71	2 Jun. 71	3 Apr. 72	4 Nov. 72	5 Nov. 72	6 Sep. 73	7 Nov. 73	8 Dec. 73	9 Apr. 74	10 Jun. 74	11 Nov. 74	
Forecasts of Levels			Percent Error											
1	GDPR	Gross domestic product	2.70	0.13	-1.75	-0.45	-1.03	1.17	-0.05	0.44	-0.95	-0.25	0.08	180.17
2	XIR	Primary product	18.38	15.62	10.98	5.28	4.93	0.41	0.41	0.23	4.46	3.35	-0.06	17.03
3	X2R	Secondary product	4.67	5.24	5.73	2.29	-1.36	0.97	-1.34	-2.18	-3.08	-0.97	0.10	61.03
4	PGNP	Tertiary product	23.57	-23.88	-22.29	-21.23	-21.23	19.17	6.85	-5.31	-9.16	-4.42	-0.88	104.42
5	PGNPR%	Prices	19.77	-22.11	-19.09	1.04	0.73	0.68	-0.66	-0.83	-0.87	-0.71	0.09	5.72
6	BGSFR*	External balance	-55.46	-68.19	-64.04	-45.92	-50.62	-36.38	-38.31	-43.57	-30.15	-26.83	-9.13	-7.23
7	EGSFR*	Exports	-2.61	0.0	-1.10	5.98	6.04	5.17	4.94	3.72	-0.29	2.32	3.54	17.21
8	MGSFR*	Imports	-23.49	-20.17	-19.88	-9.37	-10.72	-7.16	-7.05	-10.31	-9.12	-6.30	-0.20	24.49
9	TFC	Federal revenues	-24.71	-29.40	-29.12	-25.67	-26.22	-24.96	-21.17	-20.38	-11.64	-4.23	-1.20	70.71
10	TFC	Income tax revenues	-26.96	-31.27	-35.21	-32.34	-32.64	-25.27	-23.32	-22.33	-14.31	-10.06	-1.10	35.50
Forecasts of Rates of Growth (%)			Error											
11	GDPR%	Gross domestic product	1.21	0.33	-0.05	1.18	0.55	0.82	-0.83	-1.25	-1.26	-0.53	0.08	6.30
12	XIR%	Primary product	3.24	2.25	0.57	2.15	2.30	2.27	2.27	2.10	2.69	1.69	-0.08	9.23
13	X2R%	Secondary product	0.44	-1.21	-0.57	1.15	-0.10	0.73	0.73	-3.17	-3.13	-0.04	0.11	8.02
14	XGR%	Tertiary product	1.33	0.59	0.12	1.04	0.73	0.68	-0.66	-0.83	-0.87	-0.71	0.09	5.72
15	PGNP%	Prices	-19.77	-22.11	-19.09	-18.07	-18.20	-12.82	-12.41	-10.58	-11.66	-5.37	-1.00	23.63
16	BGSFR%	External balance	-73.66	-90.41	-74.84	-57.63	-68.03	-62.20	-72.51	-81.43	-66.46	-61.19	-19.65	77.20
17	EGSFR%	Exports	2.16	4.42	1.87	1.14	1.20	2.72	2.03	1.21	0.50	3.32	4.07	5.34
18	MGSFR%	Imports	-14.05	-13.26	-13.12	-11.16	-12.74	-10.32	-12.47	-17.27	-12.78	-9.75	-0.77	10.40
19	TFC%	Federal revenues	-28.27	-29.25	-29.33	-25.68	-26.15	-24.59	-21.31	-20.70	-14.57	-4.57	-1.53	38.67
20	TFC%	Income tax revenues	-28.27	-29.25	-29.33	-25.68	-26.15	-24.59	-21.31	-20.70	-14.57	-4.57	-1.53	38.67
21	Average error	rate	18.27	19.86	19.37	15.01	15.66	14.07	10.49	10.90	8.41	5.89	1.53	38.67
22	Average error	rate	18.18	16.32	14.18	15.29	14.07	10.49	10.90	8.41	5.89	1.53	2.88	10.75

Columns 1 to 11 contain the errors made in the forecasts of the last column at the date shown. Actual data for 1974, tabulated in the last column, is taken as 100% for errors (E_t) in levels and as a subtraction in errors made or rates of growth. The date of publication of the official data was March 1975. The repetition of dates indicate two alternative forecasts were made at the same date. Positive signs indicate overestimations; negative signs, underestimations. * Dollar values.

Table 4-2. Errors of 7 Ex Ante DIEMEX-Wharton Forecasts: Forecasted Year 1973

Row	Symbol	Concept	1 Jun. 71	2 Jun. 71	3 Apr. 72	4 Apr. 72	5 Nov. 72	6 Sept. 73	7 Nov. 73	Actual Value 1973
Forecasts of Levels										
1	GDPR	Gross domestic product	1.55	0.00	-1.70	-0.51	-1.54	0.40	0.74	169.49
2	X1R	Primary product	14.65	13.20	10.07	10.79	3.13	-1.32	-2.47	16.59
3	X2R	Secondary product	4.25	1.66	1.10	3.66	-1.27	0.18	0.76	56.50
4	X3R	Tertiary product	-2.29	-3.23	-5.37	4.90	-2.50	0.18	1.28	96.40
5	PGNP	Prices	-7.67	-9.59	-8.49	-7.40	-7.40	-1.64	3.56	3.65
6	BGSFR*	External balance	-23.77	-35.05	-37.75	-25.74	-19.85	-1.96	4.41	-4.08
7	EGSFR*	Exports	-4.69	-4.04	-2.82	-3.85	4.83	2.51	4.90	16.34
8	MGSFR*	Imports	-8.42	-10.24	9.84	-8.23	-0.10	1.62	4.80	20.42
9	TFC	Federal revenues	-8.33	-11.70	-13.23	-10.85	-10.85	-9.68	-2.48	52.07
10	TFIC	Income tax revenues	-9.88	-12.89	-18.95	-16.99	-16.99	-8.36	-4.61	25.60
Forecasts of Rates of Growth (%)										
11	GDPR%	Gross domestic product	-0.65	-1.62	-2.06	-0.65	-0.49	0.17	0.54	7.56
12	X1R%	Primary product	4.83	4.02	3.32	4.08	4.08	4.83	3.60	0.60
13	X2R%	Secondary product	-1.82	-3.00	-3.43	-0.54	-0.54	0.32	0.23	8.88
14	X3R%	Tertiary product	-1.20	-1.84	-2.23	-1.63	-1.31	-0.82	0.36	8.09
15	PGNP%	Prices	-7.38	-8.59	-8.30	-7.50	-7.50	-2.41	3.63	12.36
16	BGSFR%	External balance	-33.82	-46.26	-55.96	-40.22	-29.88	-16.92	-8.96	39.24
17	EGSFR%	Exports	-5.97	-4.68	-3.20	-3.97	-2.35	-1.93	0.65	11.93
18	MGSFR%	Imports	-10.85	-11.58	-12.20	-10.05	-6.94	-4.31	-0.76	16.50
19	TFIC%	Federal revenues	-10.99	-13.37	-14.27	-11.47	-11.50	-11.85	-2.99	22.98
20	TFIC%	Income tax revenues	-9.64	-11.95	-13.86	-11.46	-11.46	-11.45	-6.89	22.95
21		Average error: levels	8.54	10.16	10.93	9.29	6.85	2.89	3.00	
22		Average error: rate	8.69	10.69	11.88	9.16	7.61	5.50	2.86	

Columns 1 to 11 contain the errors made in the forecasts of the last column at the date shown. Actual data for 1974, tabulated in the last column, is taken as 100% for errors (E_t) in levels and as a subtraction in errors made or rates of growth. The date of publication of the official data was March 1975. The repetition of dates indicate two alternative forecasts were made at the same date. Positive signs indicate overestimations; negative signs, underestimations. * Dollar values.

Table 4-3. Errors of 5 Ex Ante DIEMEX-Wharton Forecasts: Forecasted Year 1972

Forecasts		1	2	3	4	5	Actual Value 1972
Row	Symbol Concept	Jun. 71	Jun. 71	Apr. 72	Apr. 72	Nov. 72	
<i>Forecasts of Levels</i>							
1	GDPR	2.17	1.54	0.22	0.10	-1.09	157.57
2	X1R	9.40	8.85	6.61	6.49	-0.90	16.49
3	X2R	5.67	4.55	4.39	4.18	-0.77	51.89
4	X3R	-1.20	-1.56	-3.37	-3.46	-1.30	89.19
5	PGNP	-1.23	-2.15	-1.23	-0.92	-0.92	3.25
6	BGSFR*	0.68	-2.73	4.10	4.44	2.05	-2.93
7	EGSFR*	1.03	0.14	0.00	-0.34	7.05	14.60
8	MGSFR*	0.97	-0.34	0.74	0.46	6.22	17.53
9	TFC	0.66	-0.92	-1.84	-1.68	-1.65	42.34
10	TFIC	-2.21	-3.51	-8.65	-8.45	-8.45	20.82
<i>Percent Error</i>							
<i>Forecasts of Rates of Growth (%)</i>							
11	GDPR%	-0.51	-1.17	-1.32	-1.45	-1.41	7.27
12	X1R%	5.64	5.11	3.43	3.35	3.72	0.48
13	X2R%	-2.03	-3.16	-2.76	-2.97	-2.98	9.39
14	X3R%	-0.87	-1.26	-1.45	-1.54	-1.54	7.40
15	PGNP%	-0.67	-1.65	-1.56	-1.16	-1.46	5.67
16	BGSFR%	-5.77	-9.06	0.12	0.22	2.47	2.81
17	EGSFR%	-3.98	-4.94	-4.81	-5.21	1.91	12.76
18	MGSFR%	-4.30	-5.69	-3.94	-4.25	2.11	10.93
19	TFIC%	-3.98	-5.74	-6.68	-6.49	-6.47	15.90
20	TFIC%	-10.58	-12.08	-14.82	-14.59	-14.59	23.63
21	Average error: levels	2.52	2.63	3.12	3.05	3.04	
22	Average error: rate	3.83	4.98	4.09	4.12	3.85	
<i>Error</i>							

Columns 1 to 11 contain the errors made in the forecasts of the last column at the date shown. Actual data for 1974, tabulated in the last column, is taken as 100% for errors (E_t) in levels and as a subtraction in errors made or rates of growth. The date of publication of the official data was March 1975. The repetition of dates indicate two alternative forecasts were made at the same date. Positive signs indicate overestimations; negative signs, underestimations. * Dollar values

and 22, contain simple averages of the absolute errors in levels and growth rates of all predictions made at a given date:

$$({}^{10}\sum_i |E_t|/10) \quad \text{and} \quad ({}^{10}\sum_i |D_t|/10)$$

The selection of the variables basically was determined by the availability of official statistics. For example, the lack of some figures, such as private consumption and investment, which were last published in 1968, prevents evaluations of the accuracy of the demand projections. Another basic criterion is that the official series has not been revised conceptually, which would impede comparisons.

ANALYSIS OF THE ERRORS

The most general observation that can be made is the tendency for the absolute size of the error to decline as the time horizon of prediction shortens. The predictions for 1974, made in June 1971, have an absolute error of 18.3 percent (or 19.9 percent) in the levels, depending on which prediction is chosen, and 16.6 percentage points (18.2) in the growth rates, as can be seen in rows 21 and 22 at the bottom of Table 4-1. (Most of this average error is due to the poor prediction of the external balance; for example, without that figure the average error of 18.3 would fall to 14.2 percentage points.) By comparison in November 1974, a half year from the publication of preliminary figures, the average errors were reduced to 1.7 percent and 2.9 percentage points, respectively (the 1.7 percent figure falls to 0.8 percent if we exclude again the balance-of-payments error). This tendency to improve the precision of the estimates as their date of announcement approaches is confirmed in the predictions for 1973. The tendency also exists for the predictions for 1972, although it is less obvious given the shortness of the sample of predictions.

The same tendency appears in the case of the majority of the specific variables. For example, in Table 4-2, which contains the most observations, the errors in predicting the price level, imports, federal government income, and income taxes all follow this tendency. The absolute errors in the levels of secondary and tertiary product also follow this tendency although the result is less clear for the growth rates.

There are also some interesting apparent deviations from this pattern; we say apparent because of the small sample size even for the predictions of 1974. For the prediction of the level and rate of change of gross domestic product (GDP) for 1974, the errors do not clearly decline. Although the maximum error, 2.7 percent, is found

in column 1, the earliest prediction, the minimum, 0.5 percent, is not found in the most up-to-date prediction, but in column 7, corresponding to September 1973. It is, therefore, not apparent that the accuracy improved as we approached the date of publication.

A similar conclusion can be drawn from the errors in predicting GDP for 1973 and 1972. The amplitude of the "cycles" of prediction does not diminish. Nevertheless, given that in none of the three cases do the errors exceed the 2.7 percent obtained at the greatest "distance," one could say that the precision in predicting GDP was "good" at almost all points in time.

Another apparent exception is the prediction of exports. For all years the final errors are greater than those obtained at intermediate and even initial dates. Nearness to the date of announcement apparently led to a deterioration in predictive accuracy—with the exception of errors in the growth rates for 1972 and 1973.

What explains these two deviations, GDP and exports, from the general rule? Apart from the reduced sample size, there are particular explanations in both cases. For GDP, the so-called good prediction at almost all points is due apparently to a cancellation of the predictive errors of the components. Primary production was generally overestimated while secondary and tertiary production were underestimated. However, this is only part of the explanation. The predictions of tertiary output, the most important component of GDP, have been in general the most accurate over all time spans, never exceeding 5.3 percent in absolute error. The predictions of secondary output, although less accurate, never exceeded 5.7 percent in absolute error. In brief, the precision of the projections of secondary and tertiary production by canceling the elevated errors in predicting primary production yielded an accurate prediction of GDP.

In the case of exports there is a more obvious explanation. When the balance of payments deficit began to grow rapidly after 1972, we started a conscious predictive policy of optimism regarding exports in order to reduce the risk of being alarmist about the external disequilibrium. Consequently, we generally used the largest, reasonable values for those exogenous variables that enter the export equations such as domestic production of primary export products. The general result was an overestimate of exports after November 1972 as shown in Tables 4-1, 4-2, and 4-3. The reverse was true for imports. Both types of errors translated into the large underestimates of the deficit in the balance of payments.

This brings us to a consideration of the signs of the errors. In addition to exports we have tended to overestimate (positive sign) primary production because of a similar policy of optimistic projections,

again through positive adjustments in the econometric equation. This is especially clear in Table 4-2. On the other hand, we have regularly underestimated prices, imports, federal government revenues, and income taxes. For the last two, the underestimate is due to the imposition of the unforeseen Fiscal Reform of 1974, which increased federal revenues by about 20 billion pesos annually. As soon as the magnitude of the reform became apparent, the underestimate was reduced to less than half, as can be appreciated through a comparison of columns 8 and 9 of row 9, Table 4-1. The same is true for the income tax.

The underestimate of imports, aside from the effect of the already mentioned optimistic treatments of the external deficit and primary production, is due to an apparent increment in the import coefficient during the Echeverria administration, at least partially the result of a liberalized policy of imports.

Finally, the underestimate of prices can be explained by the unforeseen magnitude of world inflation in 1973, combined with an internal inflation generated by the excess demand of the public sector and the rapid increase in liquidity beginning in 1972. Again these errors were reduced substantially, to less than a third, as soon as these trends became clear, as can be appreciated through a comparison of columns 5 to 7, line 5 of Table 4-1.

Another convenient way of analyzing the errors is to average them according to "forecast time horizon." In this way one can appreciate the error incurred in forecasts of one, two, three, or more years of inflation. This method has been used to evaluate forecasts obtained from the U.S. quarterly econometric models in view of the great number of forecasts that they generate yearly.⁵ In our own case, given the annual nature of the model and the few forecasts included in sample size of predictions, we have not rigorously followed this approach. Nevertheless, Tables 4-4, 4-5, and 4-6 give an idea of the forecasting errors obtained from predictions made from one half to three years in advance. The basic data for the averages are obtained from the indicated lines of Tables 4-1, 4-2, and 4-3. The figures in parentheses again correspond to an alternative forecast when two forecasts were made on the same date.

Comparing rows of the three tables, one can observe the improvement in the precision of the forecasts at shorter prediction "distances." The average error in predicting the ten levels at the bottom of Table 4-4 almost diminishes by half as the forecasting time horizon shortens from three years to one-half year, that is, 18.3 percent, 11.8 percent, 6.5 percent, and 2.6 percent. The same tendency appears clearly in the price predictions in Table 4-6. The exception

Table 4-4. Average Predictive Errors (%) of Forecasts Made with Different Anticipation Periods
(Averages obtain from Tables 4-1, 4-2, and 4-3, Rows 21-22)

Forecasted Year	1/2 Year	1 1/2 Years	2 1/2 Years	3 Years
<i>1974</i>				
Average error: levels	1.65	10.49	15.01	18.27 (19.86)
Average error: rate	2.88	16.05	15.66	16.64 (18.18)
<i>1973</i>				
Average error: levels	3.00	6.85	8.54 (10.16)	
Average error: rate	2.86	7.61	8.69 (10.69)	
<i>1972</i>				
Average error: levels	3.04	2.52 (2.63)		
Average error: rate	3.85	3.83 (4.98)		
General average: levels	2.56	6.52	11.78	18.27
General average: rates	3.20	9.16	12.18	16.64

Note: The headings 1/2 year, 1 1/2 years, etc., are approximations using mid-March of the next year to that of the forecast as date when official data is known.

The general averages are the simple averages of the figures of each column.

The figures under each column were taken from the November forecasts, previous to the forecasted year. The exceptions are the figures in parenthesis, which come from the June 1971 forecasts.

Table 4-5. Average Predictive Errors (%) of Forecasts of the Real Gross Domestic Product Made with Different Anticipation Periods
(Averages obtain from Tables 4-1, 4-2, and 4-3, Rows 1-11)

Forecasted Year	1/2 Year	1 1/2 Years	2 1/2 Years	3 Years
1974				
Average error: levels	0.08	-0.05	-0.45	0.13 (2.70)
Average error: rate	0.08	-0.83	1.18	0.13 (1.21)
1973				
Average error: levels	0.74	-1.54	0.0 (1.55)	
Average error: rate	0.54	-9.49	-1.62 (-0.65)	
1972				
Average error: levels	-1.09	1.54 (2.17)		
Average error: rate	-1.41	-1.17 (-0.51)		
General average: levels	0.64	1.04	0.45	0.13
General average: rates	0.66	0.83	1.40	0.13

Note: The headings 1/2 year, 1 1/2 years, etc., are approximations using mid-March of the next year to that of the forecast as date when official data is known.

The general averages are the simple averages of the figures of each column.

The figures under each column were taken from the November forecasts, previous to the forecasted year. The exceptions are the figures in parenthesis, which come from the June 1971 forecasts.

Table 4-6. Average Predictive Errors (%) of Forecasts of the Price Level Made with Different Anticipation Periods
(Averages obtain from Tables 4-1, 4-2, and 4-3, Rows 5-15)

Forecasted Year	1/2 Year	1 1/2 Years	2 1/2 Years	3 Years
1974				
Average error: levels	-0.88	-6.85	-21.23	-22.57 (-25.88)
Average error: rate	-1.00	-12.41	-18.20	-19.77 (-22.11)
1973				
Average error: levels	3.56	-7.40	-7.67 (-9.59)	
Average error: rate	3.63	-7.50	-7.38 (-8.59)	
1972				
Average error: levels	-0.92	-1.23 (-2.15)		
Average error: rate	-1.46	-0.67 (-1.65)		
General average: levels	1.79	5.15	14.45	22.57
General average: rates	2.03	6.86	12.79	19.77

Note: The headings 1/2 year, 1 1/2 years, etc., are approximations using mid-March of the next year to that of the forecast as date when official data is known.

The general averages are the simple averages of the figures of each column.

The figures under each column were taken from the November forecasts, previous to the forecasted year. The exceptions are the figures in parenthesis, which come from the June 1971 forecasts.

appears in the GDP predictions on Table 4-5. The early forecasts of June 1971, made with three years of anticipation, have the smallest errors. We feel, however, that a larger sample of forecasts of GDP will eventually fall into the same pattern.

A COMPARISON WITH MECHANICAL FORECASTS

As mentioned above, an alternative method of forecasting would be to use a simplistic or mechanistic approach. Even without any knowledge of the economy and its recent evolution, it is easy to generate a mechanistic "forecast" with an econometric model. All that is required is a simple extrapolation of the exogenous variables, using its recent growth rates and the residuals (or errors of estimate)⁶ of the stochastic variables, using for example, the most recent historical value. The rest is simply computer work.

Since it is useful to ask which of these methods is more accurate, we have included a comparison of their errors.⁷ The only mechanical projection that is available, using the Mexican Model V, was made in April 1972, the same date as the nonmechanical forecast already presented in Tables 4-1, 4-2 and 4-3. Table 4-7 contains the comparison of both types of forecasts.

Although at first glance a comparison of lines 21 and 22 does not appear to decisively favor the nonmechanical method, in reality the latter results are superior. The substantial error reduction achieved in 1972, where the average errors in levels are halved by the nonmechanical forecasts (3.1 percent versus 6.3 percent of the mechanical forecast), is the result of the incorporation of the economic information available to the experts in the first quarter of that year.

On the other hand, the similarity of errors of the two types of forecasts for 1973 and for 1974 is due to the absence of such up-to-date information for those years in the nonmechanical forecasts. In other words, for these two years the "nonmechanical" forecasts were actually mechanically done.

CONCLUSION

The forecasting experience of the Wharton-DIEMEX Econometric Model of Mexico is encouraging about the use of this type of models for purposes of "economic meteorology" in developing countries. The accuracy of the *ex ante* forecasts, especially of the year in course and the following year, is acceptable. The average error of the sample of predictions made one-half year in advance is 3 percent; for those

Table 4-7. Error Comparison of a Mechanical Forecast Made on April, 1972 with the Nonmechanical of the Same Date

	1972			1973			1974		
	Mechanical	Non-mechanical 1	Non-mechanical 2	Mechanical	Non-mechanical 1	Non-mechanical 2	Mechanical	Non-mechanical 1	Non-mechanical 2
<i>Errors in the Forecasts of Levels: Percents</i>									
1	-0.45	0.10	0.22	-3.23	-0.51	-1.70	-4.21	-1.75	-1.75
2	8.19	6.49	6.61	15.07	10.79	10.07	13.56	10.98	10.98
3	4.16	4.18	4.39	0.48	3.66	1.10	0.31	5.73	5.73
4	-4.73	-3.46	-3.37	8.56	4.90	5.37	9.88	-6.26	-6.26
5	-0.92	-0.92	-1.23	7.40	-7.40	-8.49	-61.08	-22.79	-22.79
6	26.95	4.44	4.10	-3.92	-25.74	-37.75	-37.20	-64.04	-64.04
7	-4.45	-0.34	0.00	11.32	-3.85	-2.82	-12.89	-1.10	-1.10
8	0.74	0.46	0.74	-9.84	-8.23	9.84	-20.09	-19.68	-19.68
9	-2.79	-1.68	-1.84	-13.85	-10.85	-13.23	-30.16	-29.12	-29.12
10	-9.51	-8.45	-8.65	-20.08	-16.99	-18.95	-36.79	-35.21	-35.21
<i>Errors in the Forecasts of Rates of Growth: Differences</i>									
11	-2.03	-1.45	-1.32	3.00	-0.65	-2.06	1.08	-0.05	-0.05
12	4.95	3.35	3.43	6.44	4.80	3.32	1.36	0.85	0.85
13	-2.99	-2.97	-2.76	3.85	-0.54	-3.43	0.18	-0.57	-0.57
14	-2.92	-1.94	-1.46	4.35	1.63	-2.23	1.53	0.12	0.12
15	-1.18	-1.16	-1.56	7.32	-7.50	-8.30	19.41	-19.09	-19.09
16	22.44	0.22	0.12	33.86	-40.22	-55.96	-61.38	-74.81	-74.81
17	9.69	-5.21	-4.81	8.04	-3.97	-3.20	1.88	1.87	1.87
18	-3.92	-4.25	-3.94	12.28	-10.05	-12.20	13.59	-13.12	-13.12
19	7.73	-6.49	-6.68	13.99	-11.47	-14.27	25.73	-24.87	-24.87
20	15.85	14.59	14.52	14.36	-11.46	-13.86	28.99	-27.83	-27.83
21	6.29	3.05	3.12	9.38	8.29	10.93	22.62	19.57	19.57
22	7.37	4.12	4.09	10.75	9.16	11.88	15.51	16.32	16.32

made one and one-half years in advance it is less than 7 percent (see Table 4-4—Average Absolute Error).

Nevertheless, the tendency for the error to increase with the length of the prediction period decreases the confidence in forecasts of more than two years. The average error of forecasts made two and one-half years in advance is close to 12 percent; of those made more than three years in advance, over 18 percent.

The predictive accuracy of the variables differs substantially. In the case of GDP the error never exceeded 3 percent even for predictions over a three-year horizon. (Table 4-1, line 1) On the other hand, prices were underestimated by 23 percent (Table 4-1, line 5) and the external balance by over 55 percent in these medium-term forecasts.

The good short-run predictive accuracy that is generally obtained is apparently due to the method of incorporating the latest information available from experts and other data sources external to the model. That is, the combined method—experts and model—permits a substantial reduction in the predictive error of the current year's forecast to less than half of that made with a mechanical projection technique (Table 4-7, lines 21 and 22, for the year 1972).

If on top of the short-term precision attainable, when considerations of the scope of economic aspects that can be forecasted, the consistency obtained among them, and the excellent work discipline imposed upon the user are taken into account, then econometric models emerge as a superior tool for forecasting.

NOTES

1. For an example of an analysis of the predictive accuracy of a quarterly model of the United States see G.R. Green and L.R. Klein, "10th Anniversary, the Wharton Forecast Record: A Self Examination, *The Wharton Quarterly* 7: 2 (Winter 1972-1973).

2. See Y. Haitovsky, G. Treyz, and V. Su, *Forecasts with Quarterly Macroeconometric Models*, Studies in Business Cycles, No. 23 (New York: NBER, 1974), p. 7.

3. A more complete description of Model V can be found in A. Beltrán del Río and L.R. Klein, "Macroeconometric Model Building in Latin America: The Mexican Case," *The Role of the Computer in Economic and Social Research in Latin America* (New York: NBER, 1974), pp. 161-90.

4. For greater detail regarding this procedure, see G.R. Green and L.R. Klein, *op. cit.*

5. See Y. Haitovsky, G. Treyz, and V. Su, *op. cit.* The models analyzed are the OBE (Office of Business Economics) and Wharton quarterly models. See also G. Green and L.R. Klein, *op. cit.*

6. If the last year of the sample used to estimate the regression is not the year

previous to the forecast (e.g., if the last year is 1970 and the forecast is for 1975-1980) the necessary intermediate errors can be obtained through a calculation of residuals or "residual check." This same check is indispensable when there have been revisions of the data over the sample period used for the regressions.

7. The superiority of the nonmechanical method is well documented for studies based on the broad sample of quarterly forecasts. See Y. Haitovsky, G. Treyz, and V. Su, *op. cit.*, ch. 7.