

This PDF is a selection from an out-of-print volume from the National Bureau of Economic Research

Volume Title: The Role of the Computer in Economic and Social Research in Latin America

Volume Author/Editor: Nancy D. Ruggles, ed.

Volume Publisher: NBER

Volume ISBN: 0-87014-260-7

Volume URL: <http://www.nber.org/books/rugg75-1>

Publication Date: 1975

Chapter Title: Models of the Brazilian Economy

Chapter Author: Janes A. de Souza, Jorge V. Monteiro

Chapter URL: <http://www.nber.org/chapters/c3770>

Chapter pages in book: (p. 139 - 150)

# MODELS OF THE BRAZILIAN ECONOMY

JANES ANGELO DE SOUZA

Brazilian Institute of Economics of the Getúlio Vargas Foundation

AND

JORGE VIANNA MONTEIRO

Economics Department of the Catholic University of Rio de Janeiro

This paper is intended as a survey of quantitative model building concerned with the Brazilian economy. Part 1 gives an overall picture of the attempts so far carried on, while Part 2 points out more specific characteristics of some of these models. Part 3 is a summary-conclusion section, which one hopes will discourage further attempts along lines so far explored that have not proved very useful.

## 1. THE MODELS OF THE ECONOMY

Macromodeling of the Brazilian economy is a recent activity with which there has not yet been much experience. In general, the initiatives for macromodeling came either in connection with development plans or from some international agency. Putting aside the simple exercises with the Domar equation, we may list the following attempts:

- (a) the Ten-Year-Plan Model (1966–1976), developed in 1966 by the Ministry of Planning;
- (b) the Baer-Kerstenetzky (1966) framework for long-run forecasting;
- (c) the Three-Year Plan (PED) Model (1968–1970), also by the Ministry of Planning;
- (d) the Behrman-Klein model, by the Economic Services Research Unit of the University of Pennsylvania (1968);
- (e) the ECLA/Fukuchi model for long-run forecasting (1969);
- (f) the Naylor et al. model, developed at the Brazilian Institute of Economics of the Vargas Foundation (1970); and
- (g) the Tintner et al. econometric model (1970).

Application of a single performance format to all of these models is not easy; first, because of their different purposes; and second, due to the different volume of information available for each. Only (a), (d), and (f) underwent some kind of operational simulation, and hence presented some validation tests of their results. Both (a) and (c)—which are supposedly planning models—were used mainly as forecasting devices, although in (a) some interesting tests of alternative sets of policy parameters were performed. After sketching the main features of these various models, we shall comment, in the next section, on the different techniques and different relationships among some macrovariables introduced in the models.

*The Ten-Year-Plan Model* [4] consists of a block recursive system of 7 behavioral equations and 16 control and accounting relations, which makes it possible to trace out the repercussions of a priori specifications of policy targets on some macroeconomic variables. These targets relate to: (i) the overall growth

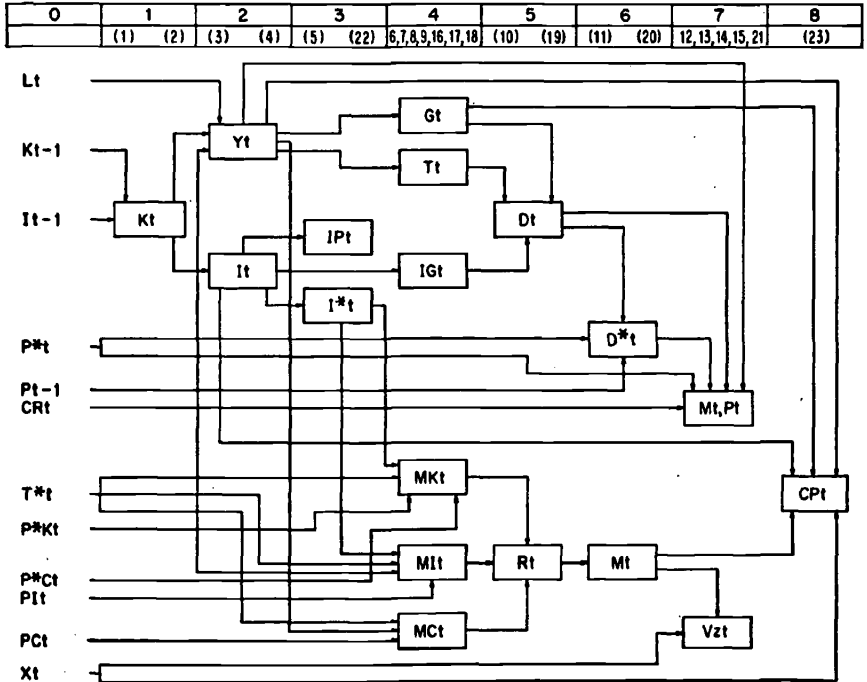

FIGURE 1 CAUSAL ORDERING OF VARIABLES IN THE TEN-YEAR-PLAN MODEL<sup>1</sup>

<sup>1</sup> The symbols used here correspond to the original source.

rate of the economy; (ii) the government share of global expenditure and inflation; (iii) the growth rate of exports; (iv) the deficit on current foreign transactions; and (v) credit expansion. The structure of the model consists of 5 blocks: Technological Restrictions, Government, Money and Banking, Foreign Trade, and Private Sector (Consumption and Investment).

The 23 basic equations, together with one auxiliary equation, trace out a chain of events from output to final consumption. A flow diagram of that structure is presented in Figure 1. The exogenous and lagged endogenous variables of zero order are shown in the first column. The variables of order two, for instance, depend on the variables of order zero, or one, or both. In general, variables of order greater than one depend only on variables of smaller order; hence Figure 1 shows that it is necessary to have the values of 12 variables to obtain the values of all subsequent series of variables in a given year. In the simulation process, the outputs at  $t$  become inputs at  $t + 1$ , with the equation:

$$K(t) = I(t - 1) + (1 - \delta)K(t - 1),$$

where  $\delta$ , for depreciation rate, is the dynamic linkage.

The *Baer-Kerstenetzky Model* [1] is a hybrid of the three-limit-type model and the Domar equation. Starting with the well-known Domar formula, the level

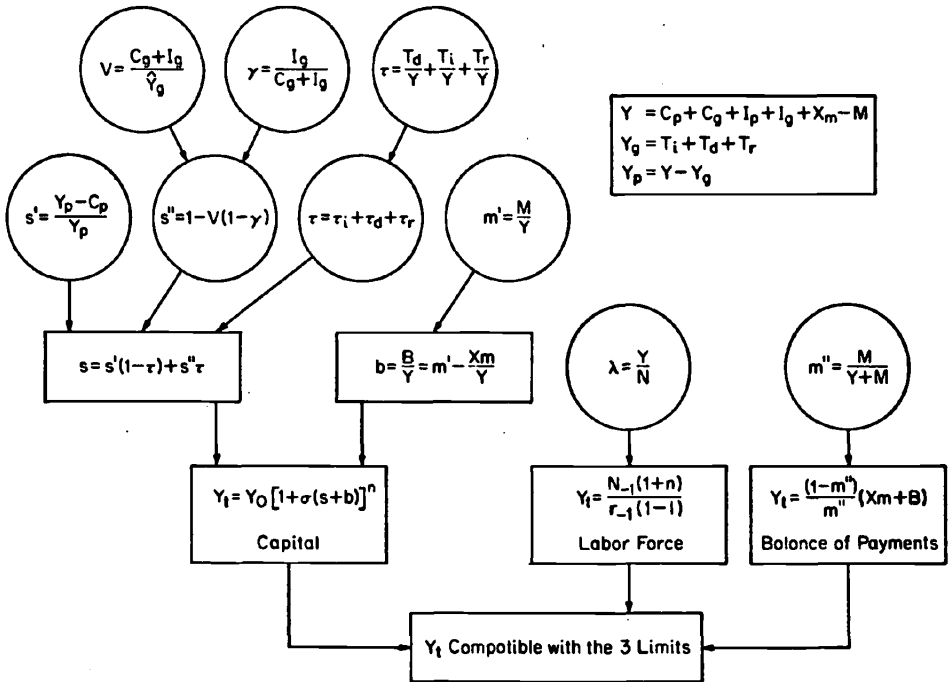

FIGURE 2 THE BAER-KERSTENETZKY MODEL<sup>1</sup>

<sup>1</sup> The symbols used here correspond to the original source.

of the National Product ( $Y$ ), in terms of the domestic and external savings rate and the marginal output/capital ratio are obtained in three stages (see Figure 2). First, the sole limitation to growth is taken to be the labor-force absorption through the identity:

$$Y(t) = \frac{N_{-1}(1+n)}{r_{-1}(1-l)},$$

in which  $N$  is the labor force;  $n$ , its annual growth rate;  $r$ , the labor/output ratio; and  $l$ , the annual growth rate of labor productivity.<sup>1</sup>

Next, taking the previous constrained rate of growth, we determine levels of domestic and external savings rates compatible with those of  $Y(t)$ . Finally, having determined the foreign savings rate, we proceed to forecast  $Y(t)$  through the identity:

$$Y(t) = \frac{(1-m)}{m}[X(t) + B(t)],$$

<sup>1</sup> In Baer-Kerstenetzky [1], the magnitudes were:  $n = 3$  percent,  $l = 2.9$  percent (average in 1940-1960) and 3.2 percent (recent trend). Taking  $(t-1)$  as 1957-1960, the alternatives for overall growth by 1975 would be 6.08 and 6.41 percent.

where  $m$  is the share of imports in the aggregate supply;  $X$ , the capacity to import; and  $B$ , the deficit on current transactions.<sup>2</sup>

After the projections were made, the main conclusion reached was that the balance of payments represents a crucial problem, from an aggregate point of view, for the long-run growth of the Brazilian economy.

*The PED Model* [5] gives the macroeconomic structure of the Three-Year Plan (1968–1970) and is by far the most complex model so far presented for Brazil.<sup>3</sup> It intends to maximize the overall growth rate of the economy constrained by inflation ceilings, by the behavior of some economic agents, and by consistency requirements. The main instrumental variables for policy purposes are taxes, government consumption and investment, and relative prices of imports.

In order to obviate some well-known difficulties of technological restriction, the model distinguishes between effective and potential output, defining accordingly a rate of capacity utilization. Taking  $z(t)$  as the ratio  $Y(t)/Y^p(t)$ , where  $Y^p(t)$  is the potential output,  $z(t)$  acts as a proxy for the pressure of demand on prices. The technological restriction is given by

$$\Delta Y(t) = 0.332I_f(t - 1) - 23.0D + 10.67,$$

where  $I_f$  is fixed investment, and  $D$  is a dummy for capacity utilization (underutilization, according to experts, would have occurred in 1953, 1956, 1963, and 1964). It is then assumed that by 1975 the Brazilian economy will be operating at full capacity, defined as

$$Y(t) = 0.95[10.67 + 0.322I_f(t - 1)],$$

implying an annual rate of investment of 17.8 percent in 1975, if the economy were to grow at 6.2 percent.

*The Behrman-Klein Model* [2] is a 44-equation model, where boldness goes along with sophistication. The equations encompass variables such as price averages of Egyptian and United States cotton, in New York, in current United States cents per pound, "average price of synthetic fabrics in New York," "government military consumption expenditures," "marginal real tax rate on agricultural added value," and so on. Especially in the foreign sector, the model offers a unique treatment of exports—so far treated as an exogenous variable in all other models presented for the Brazilian economy.

Again the scant information available to the writers precludes a more specific comment on the performance of the model, and makes one wonder where some of the data series came from, and how helpful it can be to have variables such as the ones cited in a model of the Brazilian economy, even when they are treated as exogenous. However, the innovations introduced by Behrman-Klein should not be overlooked.

*The ECLA/Fukuchi Model* [3] is basically a recursive framework for long-term forecasts (up to 1980). It consists of some 66 equations, disaggregated by regions

<sup>2</sup> In Baer-Kerstenetzky [1], it is supposed  $m = 8.53$  percent, and in some cases,  $m = 6.13$  and 5.86 percent.

<sup>3</sup> Unfortunately the formal sophistication of this model is not accompanied by methodological rigor. Also the scarce information available precludes any serious appraisal of it as a programming tool.

(five) and sectors (three). Although limited in its "universalism" to Latin America, it contains a number of relevant points: (i) population, interregional migration, and labor force are taken endogenously; (ii) regionalization is introduced—though quite primitively; (iii) an attempt is made to achieve consistency of ad hoc data with the National Accounts estimates (especially the series on capital stock).

Given the fact that the basic structure of the model is very simple, Fukuchi's forecasts are surprisingly in accord with projections made by other macromodelists. The GDP growth rate in the seventies is set at 6.7 percent (quite the same as that recently announced by the Vargas Foundation).

*The Naylor et al. Simulation Model* [7] is a more recent attempt, covering the period 1947–1968. Its structure is quite simple and similar to an earlier model by Liu-DeVries.<sup>4</sup> Basically, this model reflects the first attempt of a model-building research unit established on a permanent basis (at the Brazilian Institute of Economics of the Vargas Foundation), and as such, it is a pedagogical device and should not be viewed as a definitive result. However, simulation tests show a remarkably good performance of the model, especially when compared with the Liu-DeVries model.

*The Tintner et al. Econometric Model* [8] is just a modest exercise on time series. This model describes the Brazilian economy through the use of five equations, only two of which are behavioral, and is merely a pedagogical device. The practical result arrived at, for the period 1953–1964, was simulated values overestimating the observed results by an average margin of over 100 percent.

## 2. SECTORS AND SPECIFICATIONS

*Technological restrictions.* Data problems rather than theoretical reasons have limited the use of overall production functions in models of the Brazilian economy. The simplest forms have to make allowance for the unreliable capital-stock and factor-shares data. The direct estimation of the parameters of a Cobb-Douglas function, for instance, implies negative values for capital productivity—which is an unacceptable result. Some preliminary results of the use of different estimation procedures (nonlinear techniques) performed by one of the authors seem encouraging, given the unreliability of the input data.

RECENT ESTIMATES OF COBB-DOUGLAS-TYPE FUNCTIONS FOR THE BRAZILIAN ECONOMY

$$Y(t) = e^{\lambda} L^{\alpha} K^{\beta(t)}$$

Author	Base period	$\lambda$	$\alpha$	$\beta$
(1) Ten-Year Plan	1947–1965	1.14%	0.60	0.40
(2) Maneschi-Nunes	1947–1960	1.63	0.73	0.27
(3) Naylor et al.	1947–1968	2.20	0.73	0.27

Note: In (3) the estimates are based on the results obtained in (2), except for the estimates of  $\lambda$ .

<sup>4</sup> "An Econometric Analysis of Inflation and Growth in Brazil" (mimeographed), presented at the New York meeting of the Econometric Society, December 1969.

A popular variant to avoid the shortcomings of using a production function in econometric models of Brazil is the introduction of demand equations. That was done in the Liu-DeVries and Behrman-Klein models and, in general, in models where the output is disaggregated.

DEMAND EQUATIONS IN SOME MODELS OF THE BRAZILIAN ECONOMY

Liu-DeVries (1953-1964)	$Y_1(t) = 0.022A(t) - 141.4$	$R^2 = 0.89$
	$A(t) = 5.79P_1(t - 1) + 9.28C(t) + 9148$	$R^2 = 0.89$
	$Y_2(t) = 0.247C(t) - 25.2$	$R^2 = 0.68$
	$Y_3(t) = 1.31G(t) + 234.7$	$R^2 = 0.76$
Behrman-Klein (1948-1964)	$Y_1(t) = 3.08POP(t) - 71.12$	$R^2 = 0.93$
	$Y_2(t) = 0.2586I(t) + 0.2412C(t) - 13.39$	$R^2 = 0.96$
	$Y_3(t) = 1.538I_g(t) + 1.343C_g(t) + 77.76$	$R^2 = 0.94$

Note:  $Y_1$ ,  $Y_2$ ,  $Y_3$ , respectively, output of primary, secondary, and tertiary sectors;  $P_1$ , agricultural prices;  $A$ , harvested land;  $C$ , total consumption;  $G$ , government expenditure;  $I$ , total investment;  $I_g$ , government investment;  $C_g$ , government consumption;  $POP$ , population.

Depending upon which specification is chosen, there are questions that can, or cannot, be treated analytically in the model. A production function reflects the technological restriction of the economy and, hence, traces the effects of changes in the utilization of inputs and technological change—an essential concern in a long-term model and an important question in a short-run model. But in the field of macroeconomic data there is, perhaps, no basis for favoring the aggregate consumption or investment time series, for example, over labor or capital data; and hence, the choice between the production function and demand functions should be based on theoretical reasons.

*Investment.* Capital formation is usually broken down into private fixed investment, government fixed investment, changes in inventories, and depreciation. The results obtained in the models so far presented relative to private fixed investment are quite acceptable. The investment functions  $I_p(t)$  dismiss the rate of interest as an explanatory variable. It is not clear if this is due to the narrow influence of the capital market upon investment, or due to the difficulty in getting reliable data on interest. On the other hand, a connection with the monetary sector is obtained through an inflation coefficient—usually significant and of positive sign.<sup>5</sup> Naylor et al. got for 1948-1968:

$$I_p(t) = 0.638\Delta GDP + 0.581 \frac{\Delta P}{P_{-1}} + 33.269 \quad R^2 = 0.635$$

Other possible specifications involve credit availability to the private sector, the inflow of foreign capital, and import capacity. Liu-DeVries, however, report that they did not get significant results when they correlated credit availability and inflow of foreign capital with the inflation rate and the growth of GDP.<sup>6</sup> Also, in recent years, the capacity to import has been shown to give meager results. Perhaps due to all of this, Behrman-Klein introduce a specification in terms of

<sup>5</sup> For an interpretation of this result, see, for instance: W. Baer, *Industrialization and Economic Development in Brazil*, Homewood, Ill.: Richard D. Irwin, 1965.

<sup>6</sup> Liu and DeVries, *op. cit.*, p. 13, footnote 9.

“nonwage factor payments” and lagged inventory changes. The fact that the first variable is significant in 1948–1964 could mean that private investment was fundamentally dependent on internal funds. However, an  $\bar{R}^2$  of 0.79 does not reinforce that conclusion very much.

As to the change in inventories, attempts to associate it with changes in prices, national income, and similar factors, have invariably led to poor results. But this is not surprising when we check on the composition of this figure in the Brazilian National Accounts. It consists of variations in (i) livestock; (ii) coffee stocks; (iii) stock of import-export farm products; and (iv) stocks held by government firms. Some components, such as (ii), are related to autonomous export policies and to undesirable accumulations. Hence, the variable is introduced through a definition (Liu-DeVries, Behrman-Klein) or added to private investment (Naylor et al.).

INVESTMENT SECTOR IN SOME MODELS OF THE BRAZILIAN ECONOMY

Naylor et al. (1947–1968)	$I_p(t) = 0.635\Delta PIB(t) + 0.581 \frac{\Delta P}{P_{-1}} + 33.269$ $K(t) = K(t-1) + I(t)$ $I(t) = I_p(t) + I_o(t)$	$R^2 = 0.63$
Liu-DeVries (1953–1964)	$I_p(t) = 0.663\Delta PNB(t) + 1.58 \frac{\Delta P}{P_{-1}} + 76.8$ $I_o(t) = 0.252T(t) - 12.8$ $\Delta INV(t) = PNB(t) - C(t) - I(t) + B(t)$ $I(t) = I_p(t) + I_o(t)$	$R^2 = 0.64$ $R^2 = 0.88$
Behrman-Klein (1948–1964)	$I_p(t) = 0.2729 \frac{(L + Y_1 - TD)}{P} - 0.1740\Delta INV(t-1) - 17.06$ $\Delta INV(t) = \frac{PNB(t)}{P(t)} - C(t) - B(t) - DPR(t) - RS(t) - F(t)$ $DPR(t) = 0.02532K + 1.498$ $DPR_p(t) = \frac{\sum_{1948}^{64} I_{p(t)}}{\sum_{1948}^{64} I_{(t)}} DPR(t)$ $DPR_o(t) = DPR(t) - DPR_p(t)$ $K(t) = K(t-1) + I(t)$ $I_o(t) = 0.1418 \frac{T(t)}{P(t)} + 0.1036TK(t) + 0.044$	$R^2 = 0.79$ $R^2 = 0.97$ $R^2 = 0.86$

Note: In addition to the self-explanatory symbols, *INV* is change in inventories; *B*, deficit on current transactions; *RS*, net factor payments to abroad; *TK*, capital transfers to Brazil.

*Public Sector.* As to government equations, the models usually explore a narrow band of government activities—a serious shortcoming if the models intend to depict the possible effects of policy measures. The Ten-Year-Plan Model only explores limited questions on fiscal policy, to the extent that it tests alternative values of the size of government investment, fiscal burden, and public debt.

## GOVERNMENT SECTOR IN SOME MODELS OF THE BRAZILIAN ECONOMY

Liu-DeVries (1953-1964)	$T(t) = 0.295PNB - 149.8$	$R^2 = 0.97$
	$TR(t) = 3.58POP - 145.1$	$R^2 = 0.93$
	$SUB(t) = 67.53P_3/P_2 + 82.5$	$R^2 = 0.63$
	$Ig(t) = 0.252T(t) - 12.8$	$R^2 = 0.88$
	$D(t) = G(t) + Ig(t) + TR(t) + SUB(t) - T(t) - O(t)$ $E(t) = G(t) + Ig(t)$	
Behrman-Klein (1948-1964)	$Ti(t) = 0.729OT(t) - 6.255$	$\bar{R}^2 = 0.99$
	$Td(t) = 0.1323L(t) + 0.1557Y_1P + 2.405$	$\bar{R}^2 = 0.99$
	$Ig(t) = 0.1418 \frac{T(t)}{P(t)} + 0.1036TRK(t) + 0.044$	$R^2 = 0.86$
	$DEPg(t) = DEP(t) - DEP_p(t)$ $T(t) = Ti(t) + Td(t)$ $E(t) = G(t) + Ig(t) + DEPg(t)$ $D(t) = E(t) + TR(t) + SUB(t) - T(t)$	

Note:  $T$ , total taxes;  $TR$ , current transfers;  $SUB$ , subsidies;  $P_3/P_2$ , ratio of price indexes of transportation and communication to general wholesale index;  $D$ , deficit;  $G$ , government consumption;  $Ig$ , government investment;  $O$ , other government receipts;  $L$ , other nonagricultural factor payments;  $Y_1$ , value added in the primary sector;  $P$ , implicit deflator of GDP.

## IMPORT FUNCTION IN SOME MODELS OF THE BRAZILIAN ECONOMY

PED Model (1948-1964)	(1)	$M_1(t) = 1.03941J_f(t) - 0.3139 \frac{PM(t)}{P(t)} - 0.0310t + 3.719$	$\bar{R}^2 = 0.86$
	(2)	$MTR(t) = \text{exogenous}$	
	(3)	$MSEr(t) = \text{exogenous}$	
	(4)	$M(t) = M_1(t) + \overline{MTR} + \overline{MSEr}$	
	(5)	$RLE(t) = \text{exogenous}$	
Naylor et al. (1947-1968)	(6)	$M(t) = 1.1091(t) - 0.097TXC(t) - 0.805$	$R^2 = 0.887$
Liu-DeVries (1953-1964)	(7)	$MF(t) = 0.056I(t) + 9.65$	$R^2 = 0.56$
	(8)	$MI(t) = 0.361(t) - 4.01t - 18.9$	$R^2 = 0.66$
	(9)	$MK(t) = 0.201(t) - 0.27TXCK(t) - 1.67$	$R^2 = 0.73$
	(10)	$RES(t) = 0.151 + 1.04$	$R^2 = 0.67$
	(11)	$M(t) = MF(t) + MI(t) + MK(t) + RES(t)$	
Behrman-Klein (1948-1964)	(12)	$MF(t) = 0.00265(Y_2 + Y_3) + 0.154Xm(t) + 0.2856MF(t-1) - 1.550$	$R^2 = 0.89$
	(13)	$MK(t) = 0.1479 \frac{TXC(t)}{P(t)} + 0.1511I(t) + 13.853$	$R^2 = 0.47$
	(14)	$MC(t) = 0.03568 \frac{TXC(t)}{P(t)} - 0.00403C(t-1) + 5.514DUM + 14.19$	$R^2 = 0.66$
	(15)	$RES(t) = 0.1940Xm(t) - 0.1461 \frac{TXC(t)}{P(t)} + 0.4299TRK(t) + 12.01$	$R^2 = 0.43$
	(16)	$M(t) = [MF(t) + MK(t) + MC(t) + RES(t)] \frac{PM(t)}{P(t)}$	

Note: (i) The original form of (1) is logarithmic; (ii) in (1), (6), (12) to (16), the magnitudes are 1953 Cr\$, while in (7) to (11), 1959 Cr\$; (iii) symbols adopted are self-explanatory except for  $RLE$ , net income to abroad;  $MF$ , imports of fuels;  $MI$ , imports of raw materials;  $MR$ , imports of capital goods;  $RES$ , residual imports;  $Y_2$  and  $Y_3$ , respectively, value added in the secondary and tertiary sectors;  $TRK$ , capital transfers to Brazil.

*Foreign Trade.* The equations of the foreign sector of an econometric model may be expressed in terms of the export-import of goods and services, and of the export-import of capital.

As to exports, this variable is usually taken as exogenous, being determined by autonomous policy decisions. The endogenous treatment presents great difficulties, and the attempts that have been made to estimate the behavior of Brazilian exports have led to considerable forecasting errors. However, Behrman-Klein offer valuable suggestions in explaining the level of exports through the model.

On the other hand, imports (as shown in the comparison in the table below) present countless possibilities for inclusion in a model of the Brazilian economy. In most of the cited attempts, it is the most complete sector. Because of their critical nature, fuels are usually shown separately from other raw materials (Behrman-Klein, Liu-DeVries). The ratio of the exchange rate to a domestic price index enters significantly in most of the specifications (except fuels). The import capacity (Behrman-Klein) and the exchange rate (Behrman-Klein, Liu-DeVries, Ten-Year Plan) are the only variables which introduce the effects of commercial policies. Little attention has been paid to the movements of short-run and long-run capital.<sup>7</sup>

*Consumption.* This is no doubt the weakest part of any model of the Brazilian economy, due to the lack of data, or to the extreme unreliability of available estimates. When coupled with the well-known difficulties of econometric estimation, it becomes quite difficult to obtain any good results through a consumption function. For this reason, the Ten-Year Plan takes  $C(t)$  as residual, exactly as in the National Accounts estimates.

Among some results available, we have Rizzieri's result for 1948-1964:<sup>8</sup>

$$C_p(t) = 0.631 Y_d(t) - 52.64 \frac{\Delta P}{P_{-1}} + 0.224 C_p(t-1) + 16.866, \quad R^2 = 0.995$$

where  $C_p$  is personal consumption;  $Y_d$ , disposable income deflated by the implicit personal consumption deflator; and  $P$ , general price index.

The inclusion of the lagged variable,  $C_p(t-1)$ , is usually not significant, and certainly this hypothesis of "habit persistency" on an annual basis is weaker than on a quarterly basis, as in most models of the U.S. economy. In regard to the Brazilian economy, the test of the "forced savings" hypothesis, shown by a significant negative sign of the inflation term in the consumption function, is always interesting.

As to the inclusion of a distribution aspect, available statistical data permit only crude approximations, using some National Accounts estimates on factor

<sup>7</sup> In general, the need for foreign capital is projected through ad hoc mechanisms such as three-limit models. For a recent example of this, see Centro Latinoamericano de Proyecciones Economicas, *Proyecciones Economicas para los paises Latinoamericanos en el segun decenio de las Naciones Unidas para el desarrollo. Introduction General*, Santiago, Chile, July 1970.

<sup>8</sup> J. Rizzieri, "Função Consumo no Brasil," Instituto de Pesquisa Econômica [Institute of Economic Research], Universidade de Sao Paulo, 1968.

payments in the urban sector. For instance, as in Rizzieri,

$$\frac{C_p(t)}{Y_d(t)} = 0.9554 \frac{L}{W} + 1.25, \quad R^2 = 0.634$$

where  $L/W$  stands for "nonlabor"/"labor" factor payments.

A recent estimate comes from Naylor et al. for 1947-1968:

$$C_p(t) = 0.8949 Y_d(t) - 131.1489 \frac{\Delta P}{P_{-1}} + 1.9894. \quad R^2 = 0.996$$

### 3. CRITICAL APPRAISAL

The various models mentioned above have been sporadic attempts. As we have said before, the major experiments came from an occasional necessity to give form to the strategy of a development plan. Even now there is little activity on model building on a more permanent basis in Brazil. We may list in this respect the activities of the research units at the Catholic University of Rio de Janeiro and at the Brazilian Institute of Economics of the Vargas Foundation.

This lack of continuity has negative implications in terms of methodological improvement and technical knowledge. For instance, the advantages or disadvantages of the Ten-Year-Plan Model were not taken into consideration when the Three-Year-Plan Model was built. The experience and methodological rigor of the first attempt were forgotten in the second. In fact, only recently has an attempt at surveying the models of the Brazilian economy been made.<sup>9</sup>

The sketches of the analytical treatment in various models surveyed suggest a specific group of comments. The growing complexity of policy questions makes it necessary to include a greater number of policy variables in the models, especially as regards expansion and improved accuracy of the government equations; for example, more detail in government expenditures, in terms of broad categories such as education, health, and housing. On the other hand, to the extent that the share of state and local budgets assumes growing relevance, we should not insist on having a single aggregate variable for government. That aggregation overlooks the possibility of singling out an important instrument of regional development, such as the fund transfers from federal to state and local levels (which, in 1969, amounted to some 1.2 billion Cr\$).

The sensitivity of the GDP to changes in government global expenditures is easy to assess, as in the models we surveyed; however, it seems that nowadays the relevant policy questions require more detail: what is the possible impact on labor-force absorption of an increase of investment by the Housing Bank, or which are the implications of a fiscal-federalism type of policy vis-à-vis the global structure of the Brazilian economy in the next decade.

In order to face such questions we need a different model from those already described. There exist large amounts of data which could be included in such a macroeconomic model. As to the government sector, there are great possibilities

<sup>9</sup> Jorge Vianna Monteiro, "Uma Análise de Macromodelos da Economia Brasileira—Relatório de Pesquisa," PUC-RJ, Depto. de Economia, Jan. 1971.

in current research being done by the Ministry of Planning and the Vargas Foundation. The regional breakdown could be approached, even if on an elementary basis, following Fukuchi's attempt.

In terms of more specific themes, we would stress the necessity of analyzing the price level as an endogenous variable. Both in the Liu-DeVries and Naylor et al. models, the forecasts of the price level involve substantial error margins. In both models we could, for instance, test different hypotheses as to the Brazilian inflation, or consider an alternative treatment stating the price level through a definition, as in Behrman-Klein. Some preliminary results of the research work done by Vianna show that prices are one of the main causes of trouble in the behavior of simultaneous systems, even when introduced via a definition, rather than through a behavioral equation.

#### REFERENCES

- [1] Baer, W. and Kerstenetzky, I., "Patterns of Brazilian Economic Growth," preliminary version, presented at the conference "The Next Decade of Latin American Development," Cornell University, April, 1966.
- [2] Behrman, J. and Klein, L. R., "A Tentative Model of Brazil" (mimeographed), University of Pennsylvania, 1968.
- [3] Economic Commission for Latin America/Fukuchi, "Regional and Sectoral Projection of the Brazilian Economy," Santiago, Chile, July 1970.
- [4] Escritório de Pesquisa Economica Aplicada [Bureau for Applied Economic Research]/Ministério do Planejamento, "Bases Macro-econômica do Plano Decenal" (mimeographed), 1966.
- [5] Ministério do Planejamento, "Programa Estratégico de Desenvolvimento," 1968, 2 vols.
- [6] Monteiro, J. V., *Uma Análise de Macromodelos da Economia Brasileira*, PUC-RJ, Depto. de Economia [Department of Economics of the Pontifical Catholic University in Rio de Janeiro], Jan. 1971.
- [7] Naylor, T., Fioravante, M., and Monteiro, J. V., "A Comment on Tintner's Econometric Model of Brazil," *Revista Brasileira de Economia*, Jan.-March 1971.
- [8] Tintner, C., Consigliere, I., and Carneiro, J., "An Econometric Model Applied to the Brazilian Economy," *Revista Brasileira de Economia*, Jan.-March 1970.

